

Using Structural Equation Modeling to Investigate Students' Career Awareness in Science

Oksana Babenko

University of Alberta
obabenko@ualberta.ca

Cecilia B. Alves

University of California, Berkeley
cecilia.brito.alves@gmail.com

Louise M. Bahry

University of Massachusetts–Amherst
LBahry@educ.umass.edu

Abstract

One of the goals of education is to enable young adults to become critical evaluators of their career pursuits. Recognizing this, the objectives of this study were to: (1) develop a model of the relationships among some of the variables underlying students' career awareness in science, and (2) evaluate the model using PISA 2006 data for the United States and Canada. Results revealed that for both the USA and Canada, students' self-efficacy in science had the largest direct effect on their science proficiency. Additionally, how students perceived their science school subjects in relation to career and job prospects contributed the most to their career awareness. Findings from this study have a potential to inform educational policies and suggest mechanisms to raise students' career awareness and motivation to pursue careers in science.

Introduction

In the Programme of the United Nations Educational, Scientific, and Cultural Organization (UNESCO), the role of education is envisioned as “a means to empower children ... to become active participants in the transformation of their societies” (UNESCO Social and Human Sciences, 2009). One way to achieve this goal is by enabling young people to become critical thinkers and evaluators of their educational opportunities across subject domains and career avenues. The Organization for Economic Cooperation and Development's (OECD) Programme for International Student Assessment (PISA) is an internationally standardised assessment administered to 15-year-old high-school students every three years. With a focus on scientific literacy, PISA 2006 assesses if students near the end of their compulsory education have acquired some of the knowledge and skills essential for full participation in society (Programme for International Student Assessment (PISA) 2006a, 2006b). In addition, PISA provides quantitative measures of key variables underlying students' educational opportunities, including students' socio-

cultural backgrounds, their motivation and attitudes toward learning, as well as students' views of classroom instructional practices and school preparation for future career pursuits.

Given that one of the goals of education is to enable young adults to become critical evaluators of their career pursuits, it is important to examine some of the factors that may contribute to students' career awareness, particularly in science. Within this article, we discuss the findings of an inquiry into career awareness in science. The aim of the paper is to highlight connections between science education and career awareness factors in relation to inquiry findings. In particular, this study set out to develop a model of the relationships among the following student-related variables: (a) science proficiency; (b) demographic information, including economic, social, and cultural background; (c) science self-efficacy and enjoyment of science; and (d) students' evaluations of their learning environments, including school preparation and the role of teachers in preparing them for future careers in science. This work further aimed to evaluate the model using structural equation modeling (SEM) and PISA 2006 data. Large-scale assessments, such as PISA, and SEM are powerful tools that can provide representative and replicable results with respect to students' awareness of their educational and career opportunities as envisioned by UNESCO. Findings from this study contribute to the understanding of career awareness and suggest mechanisms that can potentially raise students' career awareness and motivation to pursue careers in science.

Theoretical Framework

Albert Bandura's (1986) social cognitive theory (SCT) provides an established framework to examine the relationships among social, affective, and cognitive variables with respect to young adults' career awareness. These three dimensions further incorporate several variables. Economic, social, and cultural background variables are examples of the social dimension; motivation, enjoyment, self-efficacy, beliefs, and attitudes depict the affective dimension; and academic achievement or proficiency represents the cognitive dimension. According to Bandura (1993), self-efficacy, for example, plays an important role in determining an individual's behaviour, because feelings of confidence with respect to a specific problem are crucial to an individual's capacity to solve that problem.

Researchers reported positive correlations between student confidence and academic performance in the domains of literacy (Marsh, Walker, & Debus, 1991; Pajares & Johnson, 1994, 1996; Shell, Colvin, & Bruning, 1995); mathematics (Hackett, 1985; Hackett & Betz, 1989; Pajares & Kranzler, 1994, 1995; Pajares & Miller, 1994, 1995); and across a variety of other academic domains (Bandura, 1993; Lent, Brown, & Larkin, 1984, 1986; Pajares, 1996; Schunk, 1985, 1989; Zimmerman, 1990, 1995). This research supports Bandura's (1986) contention that self-efficacy influences the effort and perseverance students devote to academic tasks and affects their achievement. Further, researchers explored the relationships between student confidence, college majors, and career choices, particularly in the areas of science and mathematics (Brown, Lent, & Larkin, 1989; Farmer, Wardrop, Anderson, & Risinger, 1995; Lent, Lopez, & Bieschke, 1991, 1993). Lent et al. (1993) and Hackett (1985) reported that mathematics self-confidence in college undergraduates was predictive of their interest in mathematics and their choices of math-related courses. This indicates that students' self-confidence and perceived efficacy play a highly influential role in career choices and occupational pursuits (Bandura, 2002).

Attempting to determine possible sources of student confidence in academic tasks, researchers also examined factors and experiences that can boost academic confidence. In support of SCT (Bandura, 1986), researchers suggest that past performance and vicarious experiences, including the quality of learning environments to which students are exposed, can influence student confidence. For example, Andres, Anisef, Krahn, Looker, & Thiessen (1999) and Butlin (1999) argued that students' past achievement might function as a signal about their ability to do well in present educational settings, and thus influence students' academic confidence, their choices of college major, and career aspirations. Subject-related enjoyment has also been reported to influence students' academic motivation, performance, course selection, and career pursuits. In particular, subject-related enjoyment and interest are argued to have positive effects on performance outcomes and activity choices (Lepper & Cordova, 1992). Finally, students' perceptions about their teachers and school subjects have been suggested as factors influencing students' career choices and future pursuits (OECD, 2006).

While the abovementioned studies largely focused on bivariate relationships between the variables underlying students' academic performance and career choices, the present study aims to develop a structural model using these variables simultaneously. In particular, this study uses social cognitive theory and structural equation modeling and four types of variables are attended to in order to develop a structural model with a focus on students' career awareness. These variables include students' proficiency in science; demographic information, such as economic, social, and cultural background; science self-efficacy and enjoyment of science; and students' evaluations of their learning environments, including school subjects and teachers' roles in preparing them for science-related careers. This theoretical framework shaped the investigation and helped frame three overarching research questions: a) What are the relationships among students' academic performance, self-efficacy, their evaluations of school preparation, and motivation to pursue a career in science? b) To what extent is students' career awareness influenced by their academic performance, self-efficacy, and learning environments? c) Do the hypothesized relationships (elaborated next) hold across OECD countries?

Methodology

In the proposed structural model (Figure 1), the variables of *science self-efficacy* (SCIEEFF)¹; *economic, social, and cultural status* (ESCS); and *enjoyment of science* (JOYSCIE) are hypothesized to have direct effects on student *proficiency in science* (SCIEPROF), and through it, an indirect effect on students' *career awareness* (CARAWAR). The variables of *school preparation* (SCHPREP), *teacher role* (TEACHER), *career prospects* (CARPROS), and *job prospects* (JOBPROSP) are hypothesized to have direct effects on career awareness (CARAWAR). In Figure 1, latent or underlying variables are shown in the ovals and their indicators or observed variables are shown in the rectangles.

Figure 1. Structural model

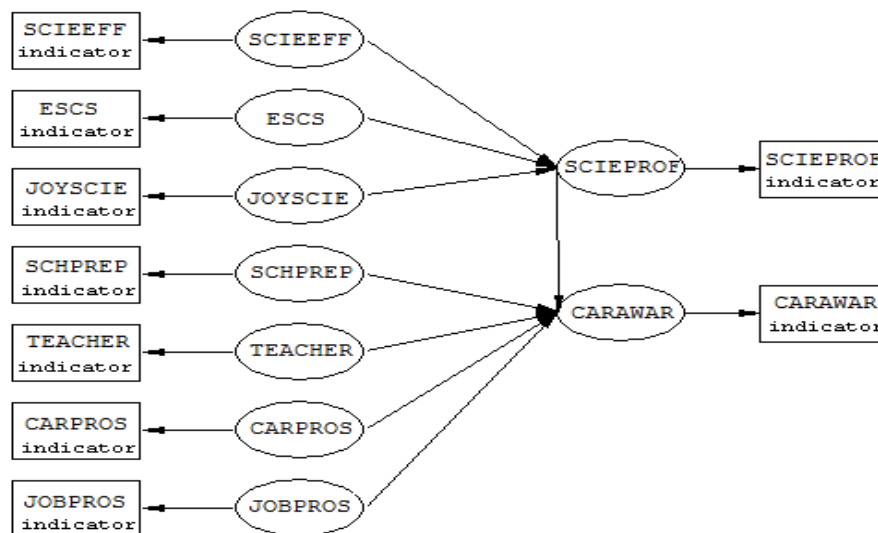

Indicators for the Latent Variables

Science self-efficacy (SCIEEFF): eight items measuring students' confidence to perform various science-related tasks were used to derive an index of science self-efficacy. Higher values on this index indicated higher levels of self-efficacy in science. The items included in the derivation of the science self-efficacy index covered the following themes: identifying scientific questions, explaining phenomena scientifically, and using scientific evidence.

Economic, social, and cultural status (ESCS): this index was derived from three family-related variables: highest parental education, highest parental occupation, and number of home possessions including books in the home. In PISA 2006, the ESCE index was derived from a principal component analysis of these three standardized variables, taking the factor scores for the first principal component as a measure of social background.

Enjoyment of science (JOYSCIE): five Likert items², all of which had been field-tested (e.g., I like reading about science; I am happy doing science problems; I enjoy acquiring new knowledge in science, etc.), were used to form an index measuring students' enjoyment of science. Higher scores on the index indicated higher levels of enjoyment of science.

School preparation (SCHPREP): school preparation for science-related careers was assessed by a Likert item indicating the extent to which students perceived themselves to be equipped with skills and knowledge needed to pursue science-related careers (i.e., The subjects I study at my school equip me with the basic skills and knowledge for a science-related career).

Teacher role (TEACHER): students' perception of their teachers' role in preparing them for science-related careers was assessed by a Likert item (i.e., My teachers equip me with the basic skills and knowledge I need for a science-related career).

Career prospects (CARPROS): students' views of their science school subjects in terms of improving their career prospects was measured by a Likert item (i.e., Studying my school science subject(s) is worthwhile for me because what I learn will improve my career prospects).

Job prospects (JOBPROS): students' view of their science school subjects in terms of helping them secure a job in the future was assessed by a Likert item (i.e., I will learn many things in my science subjects that will help me get a job).

Student proficiency in science (SCIEPROF): in PISA 2006, the level of student proficiency was computed using item response modeling to simultaneously estimate students' ability levels and the difficulty of each test item.

Career awareness (CARAWAR): career awareness was measured by a Likert item indicating the extent to which students see themselves pursuing a science-related career in the future (i.e., I would like to work in a career involving science).

Data

In this study, data from PISA 2006 were used. Administered every three years, PISA is the only international education survey measuring the knowledge and skills of 15-year-olds, an age at which students in most countries are nearing the end of their compulsory time in school. Schools in each country are randomly selected by the international contractor for participation in PISA. At each participating school, the test is administered to students whose age is between 15 years 3 months and 16 years 2 months at the time of testing, rather than to students in a specific school year. The selection of schools and students is kept as inclusive as possible so that the sample of students includes a broad range of backgrounds and abilities (PISA 2006 Technical Report, 2006b).

To test the structural model (Figure 1), first the U.S. and then the Canadian data from PISA 2006 were used. In 2006, approximately 5,600 students in Canada and 22,646 students in the USA were tested. For the purposes of this study, a sample of 400 students was randomly selected from each of the two large data sets to test the proposed structural model using LISREL (Jöreskog & Sörbom, 2006; Hayduk, 1987). Since the chi-square statistic computed in LISREL and used in evaluating model-data fit can be affected by very large sample sizes, a random sample of 400 students was deemed acceptable to reflect the relationships that may exist among the variables in each of the two large data sets. In addition to the chi-square statistic, other model-data fit indices were used to determine the goodness-of-fit of the structural model (see Table 3).

Results

First, descriptive and correlational analyses were performed to ensure that the means and standard deviations between the sample and full dataset were comparable for both countries. These analyses were also performed to provide indications of relationships existing among the variables. The results are shown in Tables 1 and 2, respectively. The structural model was evaluated using first the U.S. data, followed by the Canadian data. The results are presented and discussed in the same order.

The U.S. Data

The structural model had an adequate fit to the U.S. data in that the observed covariances of the random sample closely matched the model-implied covariances, with maximum likelihood estimates converging after 13 iterations ($\chi^2 = 7.66$ with $df = 5$, $p = .176$). The 5 df (i.e., degrees of freedom) indicated parsimony of the structural model, meaning that the structural model duplicated the observed covariance matrix of the random sample well, without allocating coefficients to each covariance (Hayduk, 1987). In addition, the model had satisfactory values for the adjusted goodness-of-fit index (AGFI), which does not depend on the sample size, as well as standardized root mean square residual (S-RMR), mean square error of approximation (RMSEA), and comparative fit index (CFI) (see Table 3). The estimates of structural coefficients confirmed most of the hypothesized relationships (see Figure 2).

Figure 2. Structural coefficients for the U.S. sample (* indicates a significant effect)

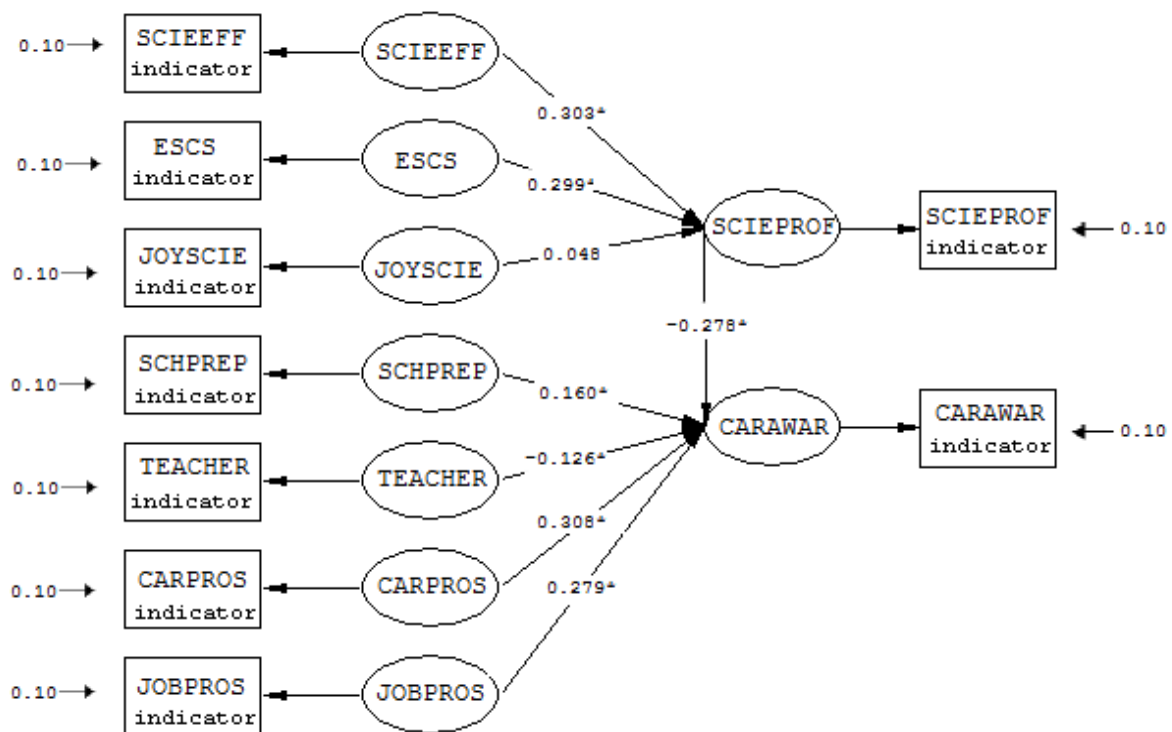

Specifically, science self-efficacy (SCIEEFF) had a direct effect on science proficiency (SCIEPROF), $\beta = .303$. The positive effect indicates that the more self-efficacious (i.e. confident) the U.S. students reported to be, the higher their proficiency was in science as measured in PISA 2006. A significant direct effect of economic, social, and cultural status (ESCS) on science proficiency (SCIEPROF), $\beta = .299$, confirmed the hypothesis that the higher the ESCS of the U.S. students, the more proficient they were in science. The positive effect of enjoyment of science (JOYSCIE) on science proficiency (SCIEPROF), $\beta = .048$ was not significant, and thus did not confirm the hypothesis about the effect of students' enjoyment of science on their science proficiency. School preparation

(SCHPREP) yielded a significant direct effect on students' career awareness (CARAWAR), $\beta = .160$, indicating that the more the U.S. students agreed that their school subjects equipped them with basic skills and knowledge needed for science-related careers, the more often they reported that they would like to pursue science careers in the future. The direct effects of career prospects (CARPROS) and job prospects (JOBPROS) on career awareness (CARAWAR) were significant, $\beta = .308$ and $\beta = .279$ respectively, confirming the hypotheses that the more the U.S. students agreed that studying science subjects would improve their career prospects (CARPROS) and help them obtain a job (JOBPROS) the more often students reported that they would like to work in science-related careers.

A direct effect of teacher role (TEACHER) on career awareness (CARAWAR), $\beta = -.126$ was significant but negative. The negative coefficient in this case suggests that, although students tended to either *strongly agree* or just *agree* that their teachers equipped them with basic knowledge and skills needed for science-related careers³, students were, nevertheless, reluctant to pursue careers in science. Finally, a direct effect of science proficiency (SCIEPROF) on students' career awareness (CARAWAR), $\beta = -.278$, was significant and in the hypothesized direction. Namely, a negative coefficient was expected because the scale for career awareness (CARAWAR) ranged from *1-strongly agree* to *4-strongly disagree*, while higher scores for science proficiency (SCIEPROF) indicated higher levels of proficiency in science. The significant effect indicated that the more proficient the U.S. students were in science, the more often they reported that they would like to work in science-related careers in the future. The total explained variance for students' science proficiency (SCIEPROF) and career awareness (CARAWAR) were $R^2 = .25$ and $R^2 = .35$ respectively, suggesting that there was some unexplained variance attributable to other factors not considered in the structural model.

The Canadian Data

Similar to the U.S. results, the structural model had an adequate fit to the Canadian data, with maximum likelihood estimates converging after 12 iterations ($\chi^2 = 9.24$ with $df = 5$, $p = .103$). The model had adequate values for the adjusted goodness-of-fit index (AGFI), standardized root mean square residual (S-RMR), mean square error of approximation (RMSEA), and comparative fit index (CFI) (see Table 3). All but one of the postulated effects were significant in the Canadian sample (Figure 3). The non-significant effect was for the direct effect of teacher role (TEACHER) on career awareness (CARAWAR), $\beta = -.094$.

Science self-efficacy (SCIEEFF) was determined to have a direct effect on science proficiency (SCIEPROF), $\beta = .446$, which was higher than the corresponding effect in the U.S. sample. The direct effect of economic, social, and cultural status (ESCS) on science proficiency (SCIEPROF), $\beta = .196$, although smaller than in the U.S. sample, confirmed the hypothesis that the higher the ESCS of the Canadian students, the more proficient they were in science. Contrary to the non-significant effect in the U.S. sample, the direct effect of enjoyment of science (JOYSCIE) on science proficiency (SCIEPROF), $\beta = .128$, was significant in the Canadian sample, confirming the hypothesis about the effect of students' enjoyment of science on their science proficiency.

Figure 3. Structural coefficients for the Canadian sample (* indicates a significant effect)

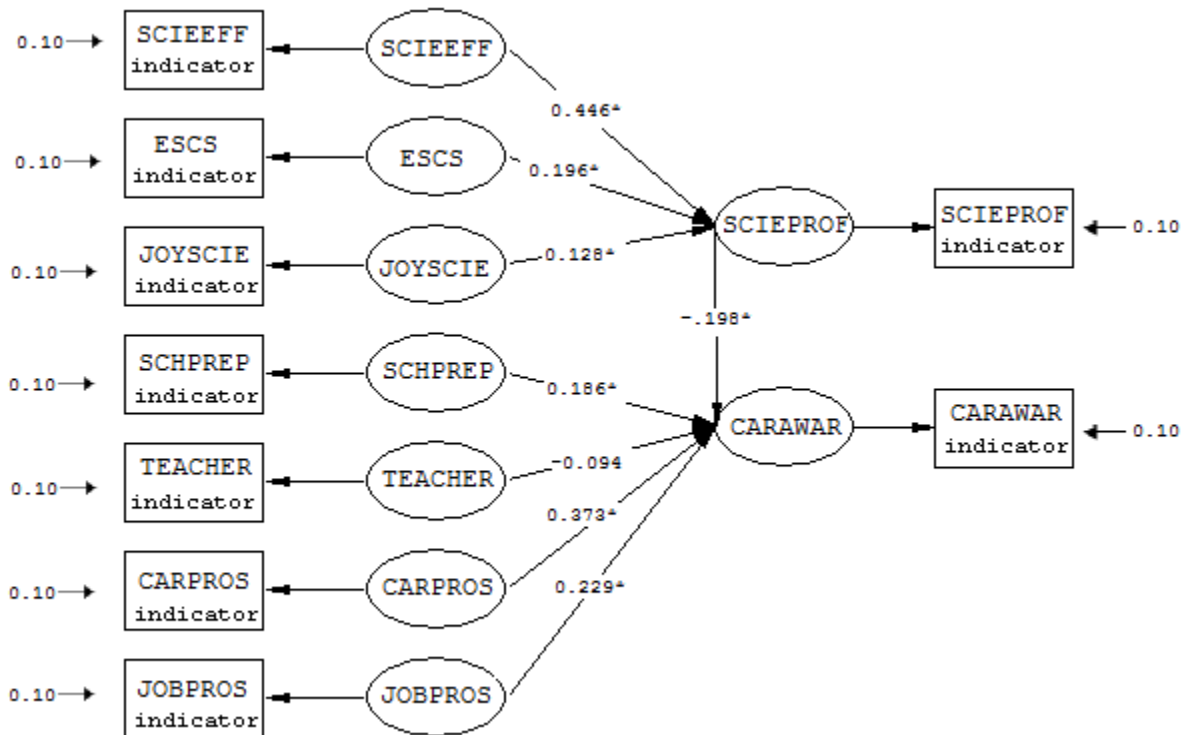

Slightly higher than the corresponding effect in the U.S. sample, school preparation (SCHPREP) yielded a significant effect on students' career awareness (CARAWAR), $\beta = .186$, indicating that the more the Canadian students agreed that their school subjects equipped them with basic skills and knowledge needed for science careers, the more often they reported they would like to pursue science-related careers. Similarly, the direct effect of career prospects (CARPROS) on career awareness (CARAWAR) was significant, $\beta = .373$, in the Canadian sample and slightly higher than in the U.S. sample. The effect of job prospects (JOBPROS) on career awareness (CARAWAR) in the Canadian sample, $\beta = .229$, was also significant, although slightly lower than in the U.S. sample. This indicated that the more the Canadian students agreed that studying science subjects would help them obtain a job (JOBPROS), the more often students reported they would like to pursue science careers. Finally, a direct effect of science proficiency (SCIEPROF) on students' career awareness (CARAWAR), $\beta = -.198$, was significant and in the hypothesized direction. Namely, a negative coefficient was expected due to the direction of the scales of the two variables. However, this effect in the Canadian sample was smaller than the corresponding effect in the U.S. sample. The total explained variance for students' science proficiency (SCIEPROF) and career awareness (CARAWAR) in the Canadian sample were $R^2 = .38$ and $R^2 = .49$ respectively.

Discussion

In this study we focused on the interplay of social, affective, and cognitive variables and their contribution in explaining students' career awareness. The results provided confirmatory evidence for some of the many factors contributing to young adults' career awareness and their proficiency in science. Except for two effects, the results for the USA and Canada were in line with the theoretical framework put forth above. In particular, in the U.S. sample, the negative relationship found between teacher role and career awareness went against the hypotheses of this study, whereas in the Canadian sample this effect was determined to be not significant.

Further, the effect of enjoyment of science on science proficiency was significant in the Canadian sample and non-significant in the U.S. sample. These differences need to be further investigated for possible reasons. The total explained variance for career awareness in the Canadian sample, $R^2 = .49$, was mostly attributable to the effects of career prospects, job prospects, and almost equally to school preparation and science proficiency. In the U.S. sample, the total explained variance for career awareness, $R^2 = .35$, was attributable almost equally to the effects of career prospects, job prospects, and science proficiency.

With respect to students' science proficiency, its explained variance in the U.S. data, $R^2 = .25$, was attributed almost equally to the effects of science self-efficacy and the economic, social, and cultural status of students. In the Canadian sample the largest contribution to the explained variance for science proficiency came from students' science self-efficacy, followed by economic, social, and cultural status; and enjoyment of science. Interestingly, students' science proficiency contributed less to the career awareness of the Canadian students than for the U.S. students.

Educational Significance

While the theoretical model proposed in this study was found to have an adequate fit for the U.S. and Canadian samples, it is necessary to investigate other cultures and/or countries as well as other possible factors contributing to young adults' career awareness. By testing the model with European and Asian samples, we may be able to make statements about more general conceptions of youths' career awareness. Further work in this area with broader international samples might bring to light motivating and unmotivating factors involved in the decisions made by young people regarding their future careers.

It might also be useful to consider the fact that models may differ substantially across cultures and/or genders. By investigating these possible differences and similarities we can add to the understanding of career awareness in general and science career awareness in particular. This vantage on cross-cultural comparative studies might contribute further to the development of more accurate and appropriate measurement and analysis tools.

Findings from this and similar studies have a potential to inform educational policies and to suggest mechanisms to raise students' career awareness and motivation to pursue careers in science. In particular, the finding that students' perceptions of their science school subjects contributed the most to career awareness brings about the question of what can be done to change students' discouraging perceptions or their potential lack of motivation. Thus, this study also encourages educators to actively help students build connections between what they learn in their science classes and a wide range of career avenues available for them to pursue in the future.

Acknowledgements

This research was supported in part by grant from the Social Sciences and Humanities Research Council (SSHRC ref.: 752-2009-1051) and the Brazilian Organization for the Promotion of Higher Education (CAPES, process number 343509-5).

References

- Andres, L., Anisef, P., Krahn, H., Looker, D., & Thiessen, V. (1999). The persistence of social structure: Cohort, class and gender effects on the occupational aspirations of Canadian youth. *Journal of Youth Studies*, 2(3), 261–282.
- Bandura, A. (1986). *Social foundations of thought and action: A social cognitive theory*. Englewood Cliffs, NJ: Prentice–Hall.
- Bandura, A. (1993). Perceived self–efficacy in cognitive development and functioning. *Educational Psychologist*, 28(2), 117–148.
- Bandura, A. (2002). Social cognitive theory in cultural context. *Applied Psychology: An International Review*, 51(2), 269–290.
- Brown, S., Lent, R., & Larkin, K. (1989). Self–efficacy as a moderator of scholastic aptitude–academic performance relationships. *Journal of Vocational Behavior*, 35(1), 64–75.
- Butlin, G. (1999). Determinants of postsecondary participation. *Education Quarterly Review*, 5(3), 9–35.
- Farmer, H., Wardrop, J., Anderson, M., & Risinger, R. (1995). Women’s career choices: Focus on science, math, and technology careers. *Journal of Counseling Psychology*, 42(2), 155–170.
- Hackett, G. (1985). The role of mathematics self–efficacy in the choice of math–related majors of college women and men: A path analysis. *Journal of Counseling Psychology*, 32(1), 41–56.
- Hackett, G. & Betz, N. (1989). An exploration of the mathematics self–efficacy/mathematics performance correspondence. *Journal for Research in Mathematics Education*, 20(3), 261–273.
- Hayduk, L. (1987). *Structural equation modeling with LISREL: Essentials and advances*. Baltimore: Johns Hopkins University Press.
- Jöreskog, K. & Sörbom, D. (2006). LISREL 8.80. Chicago: Scientific Software International.
- Lent, R., Brown, S., & Larkin, K. (1984). Relation of self–efficacy expectations to academic achievement and persistence. *Journal of Counseling Psychology*, 31(3), 356–362.
- Lent, R., Brown, S., & Larkin, K. (1986). Self–efficacy in the prediction of academic performance and perceived career options. *Journal of Counseling Psychology*, 33(3), 265–269.
- Lent, R., Lopez, F., & Bieschke, K. (1991). Mathematics self–efficacy: Sources and relation to science–based career choice. *Journal of Counseling Psychology*, 38(4), 424–430.
- Lent, R., Lopez, F., & Bieschke, K. (1993). Predicting mathematics–related choice and success behaviors: Test of an expanded social cognitive model. *Journal of Vocational Behavior*, 42(2), 223–236.
- Lepper, M. & Cordova, D. (1992). A desire to be taught: Instructional consequences of intrinsic motivation. *Motivation and Emotion*, 16(3), 187–208.
- Marsh, H., Walker, R., & Debus, R. (1991). Subject–specific components of academic self–concept and self–efficacy. *Contemporary Educational Psychology*, 16(4), 331–345.
- OECD (2006). Assessing Scientific, Reading and Mathematical Literacy. A Framework for PISA 2006. Retrieved from <http://www.oecd.org/dataoecd/63/35/37464175.pdf>
- Pajares, F. (1996). Self–efficacy beliefs in academic settings. *Review of Educational Research*, 66(4), 543–578.
- Pajares, F. & Johnson, M. (1994). Confidence and competence in writing: The role of self–efficacy, outcome expectancy, and apprehension. *Research in the Teaching of English*, 28(3), 313–331.
- Pajares, F. & Johnson, M. (1996). Self–efficacy beliefs and the writing performance of entering high school students. *Psychology in the Schools*, 33(2), 163–175.
- Pajares, F. & Kranzler, J. (1994). Self–efficacy, self–concept, and general mental ability in mathematical problem–solving. *Florida Educational Research Council Research Bulletin*, 26(1/2), 8–32.
- Pajares, F. & Kranzler, J. (1995). Self–efficacy beliefs and general mental ability in mathematical problem–solving. *Contemporary Educational Psychology*, 20(4), 426–443.
- Pajares, F. & Miller, M. (1994). The role of self–efficacy and self–concept beliefs in mathematical problem–solving: A path analysis. *Journal of Educational Psychology*, 86(2), 193–203.
- Pajares, F. & Miller, M. (1995). Mathematics self–efficacy and mathematics performances: The need for specificity of assessment. *Journal of Counseling Psychology*, 42(2), 190–198.
- Programme for International Student Assessment. (2006a). Database. Retrieved from <http://www.oecd.org>
- Programme for International Student Assessment (PISA) 2006. (2006b). PISA 2006 Technical Report. Retrieved from http://www.oecd.org/document/41/0,3746,en_32252351_32236191
- Schunk, D. (1985). Self–efficacy and classroom learning. *Psychology in the Schools*, 22(2), 208–223.
- Schunk, D. (1989). Self–efficacy and achievement behaviors. *Educational Psychology Review*, 1(3), 173–208.
- Shell, D., Colvin, C., & Bruning, R. (1995). Self–efficacy, attributions, and outcome expectancy mechanisms in reading and writing achievement: Grade–level and achievement–level differences. *Journal of Educational Psychology*, 87(3), 386–398.
- UNESCO Social and Human Sciences. (2009). *Role of education*. Retrieved from <http://www.unesco.org/new/en/social-and-human-sciences/themes/human-rights/fight-against-discrimination/role-of-education/>
- Zimmerman, B. (1990). Self–regulating academic learning and achievement: The emergence of a social cognitive perspective. *Educational Psychology Review*, 2(2), 173–201.
- Zimmerman, B. (1995). Self–efficacy and educational development. In A. Bandura (Ed.), *Self–efficacy in changing societies* (pp. 202–231). New York: Cambridge University Press.

Notes

¹In parentheses, the name of each latent variable as it appears in Figure 1 is provided.

²A Likert item is used to measure the level of a respondent's agreement or disagreement with a statement by asking a respondent to select one of the ordered options. In PISA 2006, the options are: 1–strongly agree, 2–agree, 3–disagree, 4–strongly disagree.

³As shown in Table 1, the average for this item is 1.89 on a 4–point scale (1–strongly agree, 2–agree, 3–disagree, 4–strongly disagree).

Table 1. Descriptive Statistics for the U.S. and Canadian Samples

	USA				Canada			
	Mean	SD	Min.	Max.	Mean	SD	Min.	Max.
Science proficiency	492.32	103.92	252.46	751.61	516.92	93.44	252.65	759.26
Career awareness ^a	2.49	0.93	1.00	4.00	2.55	1.02	1.00	4.00
Self–efficacy ^b	0.27	1.10	–3.76	3.22	0.22	1.13	–3.77	3.22
Socio–economic status ^b	0.12	0.87	–2.31	2.09	0.30	0.83	–2.80	2.21
Enjoyment of science ^b	–0.01	1.00	–2.15	2.06	0.09	1.03	–2.15	2.06
Subject usefulness ^a	1.98	0.67	1.00	4.00	1.99	0.75	1.00	4.00
Teacher role ^a	1.89	0.63	1.00	4.00	1.91	0.72	1.00	4.00
Career prospect ^a	2.12	0.76	1.00	4.00	2.03	0.88	1.00	4.00
Job prospect ^a	2.12	0.78	1.00	4.00	2.02	0.86	1.00	4.00

N = 400 randomly selected students from each of the two large data sets (i.e., the USA and Canada).

^a Measured on a 4–point scale (1–strongly agree, 2–agree, 3–disagree, 4–strongly disagree); i.e., the scale is inverted in PISA 2006.

^b In PISA 2006, the index was constructed through the scaling of several items, with the scale scores for the index being Weighted Likelihood Estimates (WLE).

Table 2. Zero–order Correlations for the U.S. and Canadian Samples

	1	2	3	4	5	6	7	8	9
1. Science proficiency		–.238	.518	.349	.388	–.215	–.215	–.214	–.125
2. Career awareness ^a	–.121		–.280	–.107	–.619	.409	.263	.602	.578
3. Self–efficacy	.375	–.241		.298	.475	–.264	–.248	–.212	–.218
4. Socio–economic status	.363	–.130	.282		.170	–.169	–.099*	–.136	–.098*
5. Enjoyment of science	.249	–.500	.381	.188		–.411	–.324	–.523	–.490
6. Subject usefulness ^a	–.113	.263	–.308	–.186	–.182		.628	.435	.465
7. Teacher role ^a	–.174	.152	–.297	–.085*	–.176	.542		.315	.342
8. Career prospect ^a	–.076*	.513	–.213	–.003*	–.407	.240	.228		.772
9. Job prospect ^a	–.063*	.505	–.227	–.028*	–.408	.253	.268	.722	

N = 400 randomly selected students from each of the two large data sets (i.e., the USA and Canada).

Note: The results for the U.S. sample are reported in the lower triangle and the results for the Canadian sample are reported in the upper triangle.

* Non–significant correlation coefficients at the 0.05 level.

^a Measured on a 4-point scale (1-strongly agree, 2-agree, 3-disagree, 4-strongly disagree); i.e., the scale is inverted in PISA 2006.

Table 3. Data-Model Fit Indices for the USA and Canada

Fit indices	RMR	S-RMR	GFI	AGFI	PGFI	χ^2	p (χ^2)	RMSEA	NFI	CFI
USA: df = 5	1.05	0.01	0.99	0.96	0.11	7.66	0.176	0.04	0.99	0.99
Canada: df = 5	0.97	0.01	0.99	0.95	0.11	9.24	0.103	0.04	0.99	0.99
Interpretation for fit indices										
Range	–	–	(0)–1	(0)–1	0–1	>0	0–1	>0	0–1	0–1
Good fit if	Near 0	≤.08	≥.90	≥.90	Near 1	Small	>.05	≤.05	≥.95	≥.95

Note. RMR = root mean square residual; S-RMR = standardized root mean square residual; GFI = goodness-of-fit index; AGFI = adjusted goodness-of-fit index; PGFI = parsimony goodness-of-fit index; RMSEA = root mean square error of approximation; NFI = normed fit index; CFI = comparative fit index.